

### Blair Dr Middle School Rd

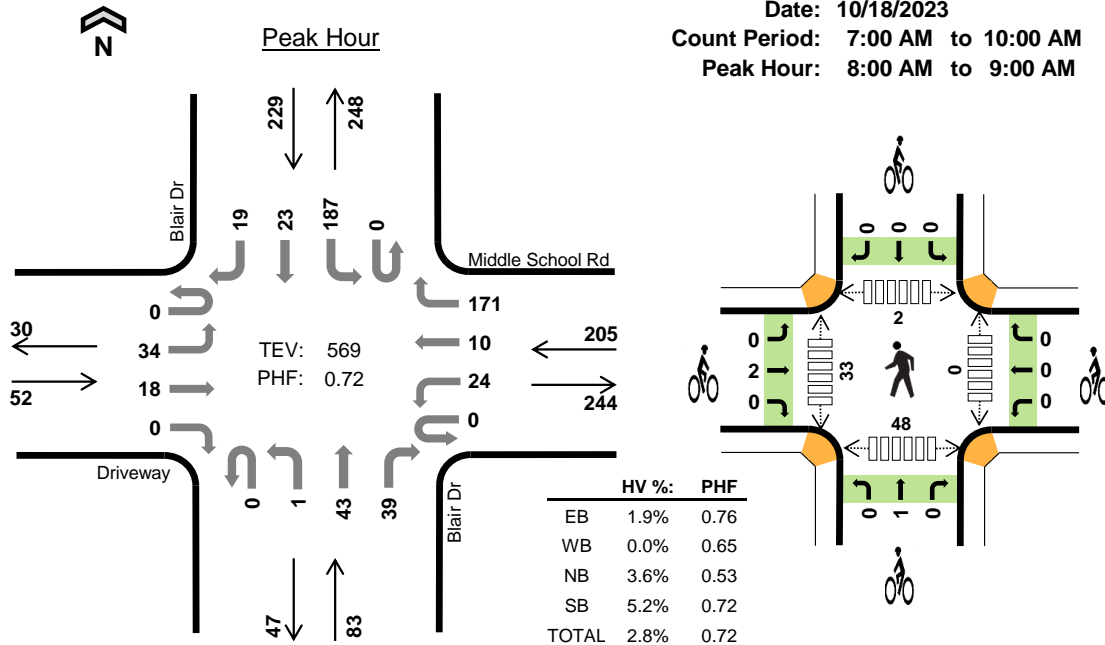

Date: 10/18/2023  
 Count Period: 7:00 AM to 10:00 AM  
 Peak Hour: 8:00 AM to 9:00 AM



#### Three-Hour Count Summaries

Interval Start	Driveway				Middle School Rd				Blair Dr				Blair Dr				15-min Total	Rolling One Hour	
	Eastbound				Westbound				Northbound				Southbound						
	UT	LT	TH	RT	UT	LT	TH	RT	UT	LT	TH	RT	UT	LT	TH	RT			
8:00 AM	0	12	5	0	0	8	4	35	0	0	8	4	0	32	2	4	114	0	
8:15 AM	0	7	1	0	0	3	0	10	0	1	9	5	0	27	15	1	79	0	
8:30 AM	0	8	8	0	0	4	3	59	0	0	10	7	0	69	4	6	178	0	
8:45 AM	0	7	4	0	0	9	3	67	0	0	16	23	0	59	2	8	198	569	
Peak Hour	All	0	34	18	0	0	24	10	171	0	1	43	39	0	187	23	19	569	0
	HV	0	0	1	0	0	0	0	0	0	0	3	0	0	9	3	0	16	0
	HV%	-	0%	6%	-	-	0%	0%	0%	-	0%	7%	0%	-	5%	13%	0%	3%	0

Note: For all three-hour count summary, see next page.

Interval Start	Heavy Vehicle Totals					Bicycles					Pedestrians (Crossing Leg)				
	EB	WB	NB	SB	Total	EB	WB	NB	SB	Total	East	West	North	South	Total
8:00 AM	0	0	1	1	2	2	0	0	0	2	0	5	0	5	10
8:15 AM	0	0	1	3	4	0	0	1	0	1	0	8	0	8	16
8:30 AM	0	0	0	8	8	0	0	0	0	0	0	10	1	19	30
8:45 AM	1	0	1	0	2	0	0	0	0	0	0	10	1	16	27
Peak Hour	1	0	3	12	16	2	0	1	0	3	0	33	2	48	83

Three-Hour Count Summaries																			
Interval Start	Driveway				Middle School Rd				Blair Dr				Blair Dr				15-min Total	Rolling One Hour	
	UT	Eastbound			UT	Westbound			UT	Northbound			UT	Southbound					
		LT	TH	RT	UT	LT	TH	RT	UT	LT	TH	RT	UT	LT	TH	RT			
7:00 AM	0	13	3	0	0	1	1	0	0	0	12	2	0	3	1	1	37	0	
7:15 AM	0	17	0	0	0	3	1	6	0	0	7	3	0	9	3	3	52	0	
7:30 AM	0	9	3	0	0	1	1	3	0	0	18	8	0	4	3	1	51	0	
7:45 AM	0	13	6	0	0	4	1	26	0	0	21	23	0	31	2	4	131	271	
8:00 AM	0	12	5	0	0	8	4	35	0	0	8	4	0	32	2	4	114	348	
8:15 AM	0	7	1	0	0	3	0	10	0	1	9	5	0	27	15	1	79	375	
8:30 AM	0	8	8	0	0	4	3	59	0	0	10	7	0	69	4	6	178	502	
8:45 AM	0	7	4	0	0	9	3	67	0	0	16	23	0	59	2	8	198	569	
9:00 AM	0	7	4	0	0	3	1	12	0	0	8	3	0	16	3	4	61	516	
9:15 AM	0	7	1	0	0	2	1	10	0	0	4	4	0	8	1	3	41	478	
9:30 AM	0	4	0	0	0	1	2	4	0	0	6	1	0	5	4	1	28	328	
9:45 AM	0	6	2	0	0	2	1	5	0	0	5	2	0	2	1	5	31	161	
Count Total	0	110	37	0	0	41	19	237	0	1	124	85	0	265	41	41	1,001	0	
Peak Hour	All	0	34	18	0	0	24	10	171	0	1	43	39	0	187	23	19	569	0
	HV	0	0	1	0	0	0	0	0	0	0	3	0	0	9	3	0	16	0
	HV%	-	0%	6%	-	-	0%	0%	0%	-	0%	7%	0%	-	5%	13%	0%	3%	0

Note: Three-hour count summary volumes include heavy vehicles but exclude bicycles in overall count.

Interval Start	Heavy Vehicle Totals					Bicycles					Pedestrians (Crossing Leg)				
	EB	WB	NB	SB	Total	EB	WB	NB	SB	Total	East	West	North	South	Total
7:00 AM	0	0	1	0	1	0	0	0	0	0	0	0	0	0	0
7:15 AM	0	2	1	0	3	0	0	0	0	0	2	0	3	2	7
7:30 AM	1	0	1	0	2	0	0	0	0	0	0	0	1	1	2
7:45 AM	0	0	1	2	3	0	1	1	1	3	0	3	0	2	5
8:00 AM	0	0	1	1	2	2	0	0	0	2	0	5	0	5	10
8:15 AM	0	0	1	3	4	0	0	1	0	1	0	8	0	8	16
8:30 AM	0	0	0	8	8	0	0	0	0	0	0	10	1	19	30
8:45 AM	1	0	1	0	2	0	0	0	0	0	0	10	1	16	27
9:00 AM	1	2	1	0	4	0	0	0	0	0	0	3	0	2	5
9:15 AM	0	0	1	0	1	0	0	0	0	0	1	0	1	0	2
9:30 AM	0	0	0	1	1	0	1	0	0	1	0	0	1	0	1
9:45 AM	0	0	1	0	1	0	0	0	0	0	0	0	0	2	2
Count Total	3	4	10	15	32	2	2	2	1	7	3	39	8	57	107
Peak Hour	1	0	3	12	16	2	0	1	0	3	0	33	2	48	83

<b>Three-Hour Count Summaries - Heavy Vehicles</b>																		
Interval Start	Driveway				Middle School Rd				Blair Dr				Blair Dr				15-min Total	Rolling One Hour
	Eastbound				Westbound				Northbound				Southbound					
	UT	LT	TH	RT	UT	LT	TH	RT	UT	LT	TH	RT	UT	LT	TH	RT		
7:00 AM	0	0	0	0	0	0	0	0	0	0	1	0	0	0	0	0	1	0
7:15 AM	0	0	0	0	0	1	1	0	0	0	1	0	0	0	0	0	3	0
7:30 AM	0	1	0	0	0	0	0	0	0	0	1	0	0	0	0	0	2	0
7:45 AM	0	0	0	0	0	0	0	0	0	0	1	0	0	2	0	0	3	9
<b>8:00 AM</b>	<b>0</b>	<b>0</b>	<b>0</b>	<b>0</b>	<b>0</b>	<b>0</b>	<b>0</b>	<b>0</b>	<b>0</b>	<b>0</b>	<b>1</b>	<b>0</b>	<b>0</b>	<b>1</b>	<b>0</b>	<b>0</b>	<b>2</b>	<b>10</b>
8:15 AM	0	0	0	0	0	0	0	0	0	0	1	0	0	0	3	0	4	11
8:30 AM	0	0	0	0	0	0	0	0	0	0	0	0	0	8	0	0	8	17
<b>8:45 AM</b>	<b>0</b>	<b>0</b>	<b>1</b>	<b>0</b>	<b>0</b>	<b>0</b>	<b>0</b>	<b>0</b>	<b>0</b>	<b>0</b>	<b>1</b>	<b>0</b>	<b>0</b>	<b>0</b>	<b>0</b>	<b>0</b>	<b>2</b>	<b>16</b>
9:00 AM	0	1	0	0	0	0	1	1	0	0	1	0	0	0	0	0	4	18
9:15 AM	0	0	0	0	0	0	0	0	0	0	1	0	0	0	0	0	1	15
9:30 AM	0	0	0	0	0	0	0	0	0	0	0	0	0	1	0	0	1	8
9:45 AM	0	0	0	0	0	0	0	0	0	0	1	0	0	0	0	0	1	7
Count Total	0	2	1	0	0	1	2	1	0	0	10	0	0	12	3	0	32	0
Peak Hour	0	0	1	0	0	0	0	0	0	0	3	0	0	9	3	0	16	0
<b>Three-Hour Count Summaries - Bikes</b>																		
Interval Start	Driveway			Middle School Rd			Blair Dr			Blair Dr			15-min Total	Rolling One Hour				
	Eastbound			Westbound			Northbound			Southbound								
	LT	TH	RT	LT	TH	RT	LT	TH	RT	LT	TH	RT						
7:00 AM	0	0	0	0	0	0	0	0	0	0	0	0	0	0	0	0	0	0
7:15 AM	0	0	0	0	0	0	0	0	0	0	0	0	0	0	0	0	0	0
7:30 AM	0	0	0	0	0	0	0	0	0	0	0	0	0	0	0	0	0	0
7:45 AM	0	0	0	0	0	0	1	0	0	0	1	1	0	0	0	3	3	3
<b>8:00 AM</b>	<b>0</b>	<b>2</b>	<b>0</b>	<b>0</b>	<b>0</b>	<b>0</b>	<b>0</b>	<b>0</b>	<b>0</b>	<b>0</b>	<b>0</b>	<b>0</b>	<b>0</b>	<b>0</b>	<b>0</b>	<b>2</b>	<b>5</b>	<b>5</b>
8:15 AM	0	0	0	0	0	0	0	0	1	0	0	0	0	0	0	1	6	6
8:30 AM	0	0	0	0	0	0	0	0	0	0	0	0	0	0	0	0	6	6
<b>8:45 AM</b>	<b>0</b>	<b>0</b>	<b>0</b>	<b>0</b>	<b>0</b>	<b>0</b>	<b>0</b>	<b>0</b>	<b>0</b>	<b>0</b>	<b>0</b>	<b>0</b>	<b>0</b>	<b>0</b>	<b>0</b>	<b>0</b>	<b>3</b>	<b>3</b>
9:00 AM	0	0	0	0	0	0	0	0	0	0	0	0	0	0	0	0	1	1
9:15 AM	0	0	0	0	0	0	0	0	0	0	0	0	0	0	0	0	0	0
9:30 AM	0	0	0	0	0	1	0	0	0	0	0	0	0	0	0	1	1	1
9:45 AM	0	0	0	0	0	0	0	0	0	0	0	0	0	0	0	0	1	1
Count Total	0	2	0	0	0	1	1	0	1	1	1	1	1	0	0	7	0	0
Peak Hour	0	2	0	0	0	0	0	0	1	1	0	0	0	0	0	3	0	0

Note: U-Turn volumes for bikes are included in Left-Turn, if any.